

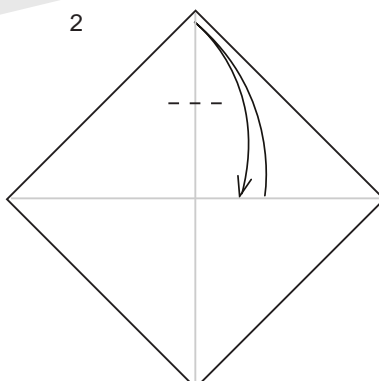

"Las antiguas culturas mesoamericanas, consideraban al jaguar como el único animal que podía equipararse con el hombre. Se creía que cada hombre llevaba en su interior un jaguar y que cada jaguar podía ser a su vez un hombre disfrazado."

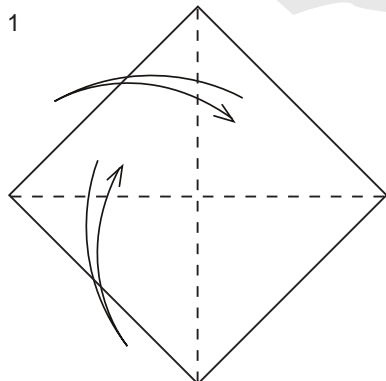

Marcar

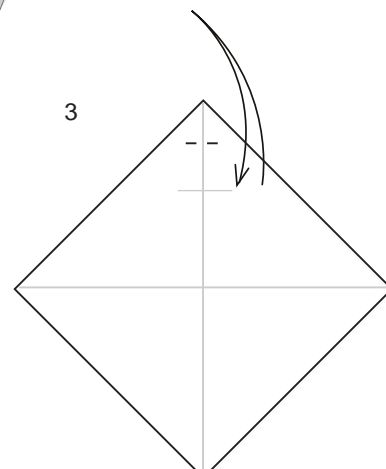

Marcar

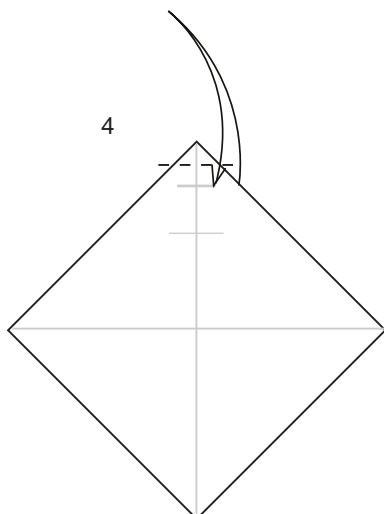

Marcar

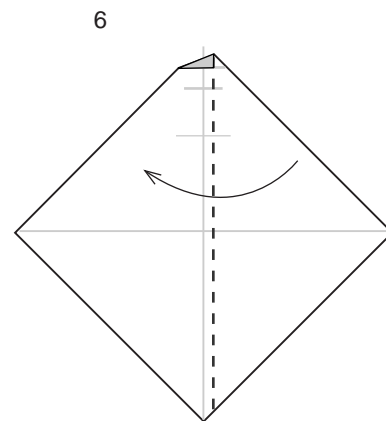
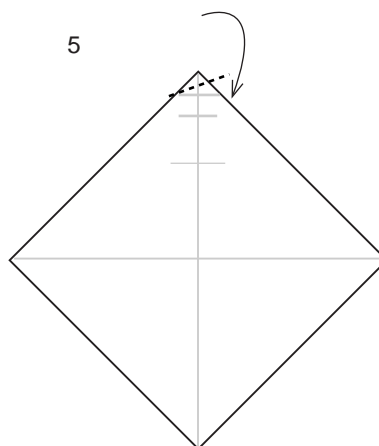

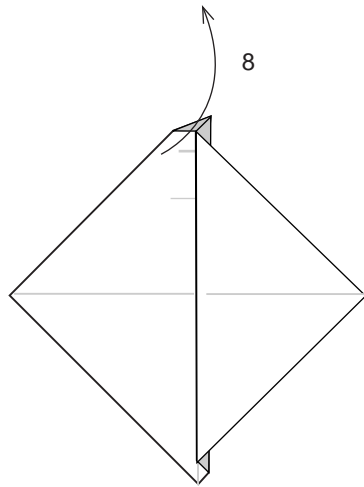
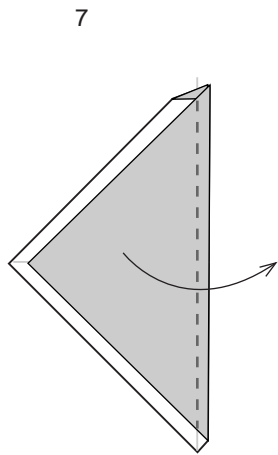

Desdoblar la punta

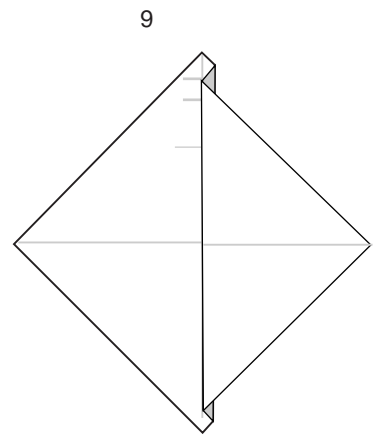

Repetir pasos 5 al 8

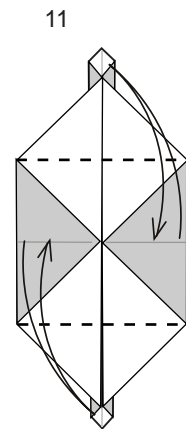
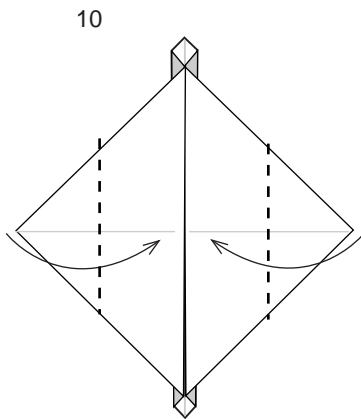

Doblar y desdoblar

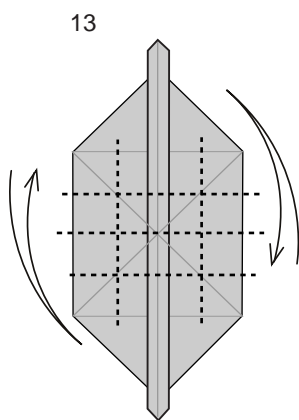
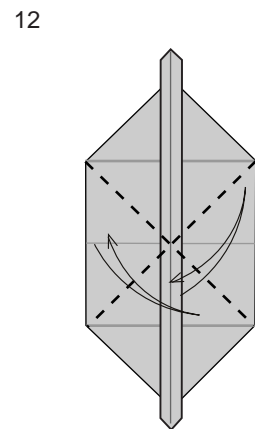
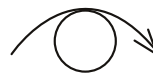

grilla de 4 x 4

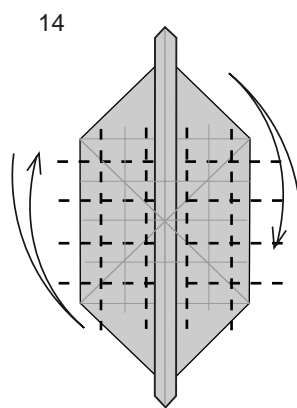

grilla de 8 x 8

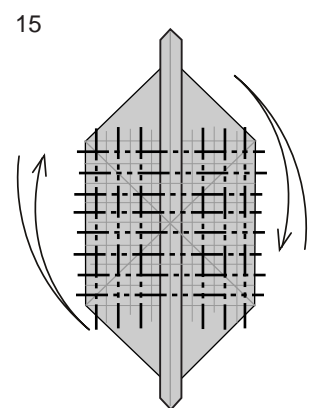

grilla de 16 x 16

16

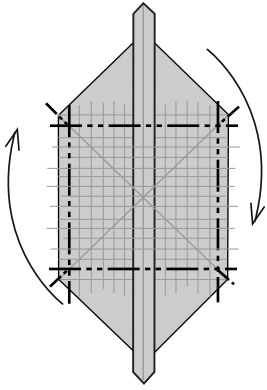

Colapsar el cuadrado central siguiendo las líneas pre-marcadas

17

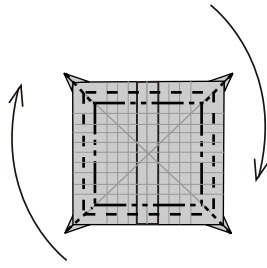

Continuar...

18

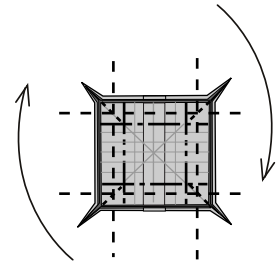

19

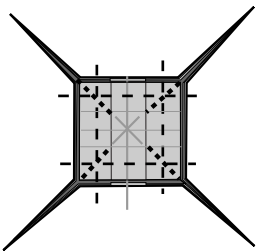

20

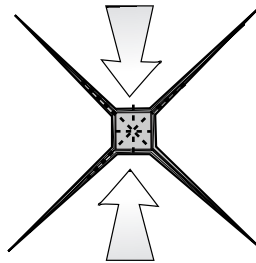

21

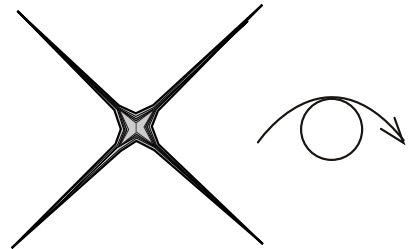

22

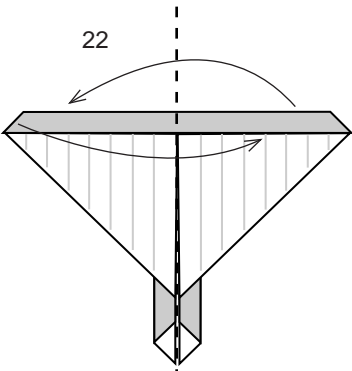

Abrir ambas puntas

23

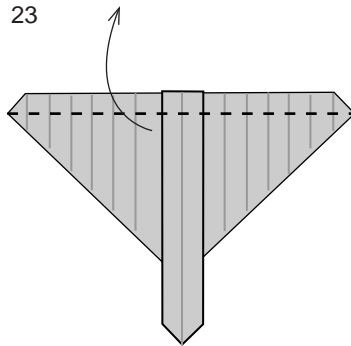

Repetir atrás

24

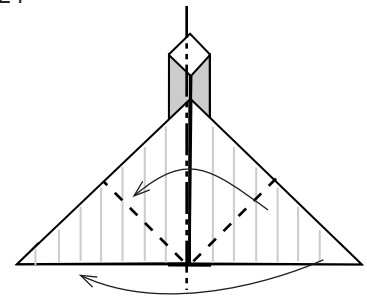

Colapsar

25

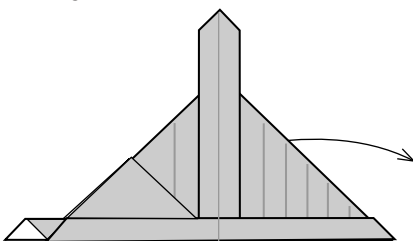

Repetir atrás

26

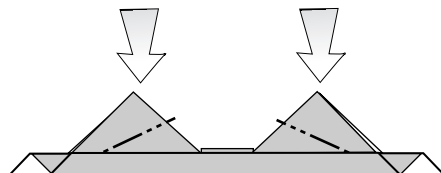

Hundir

27

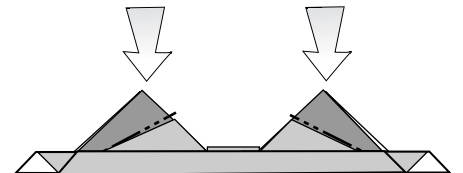

Repetir atrás

28

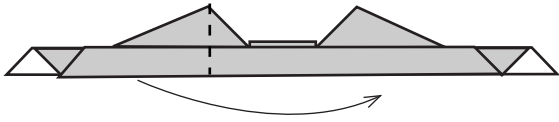

Doblar la primera capa. Repetir atrás

29

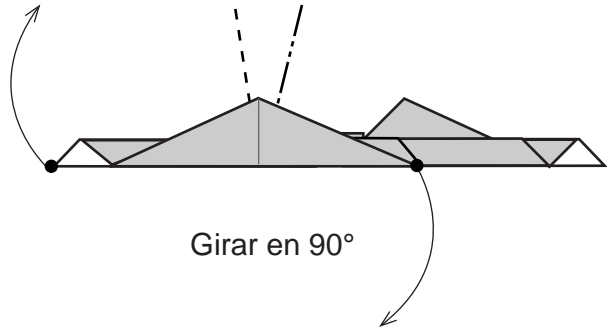

Girar en 90°

30

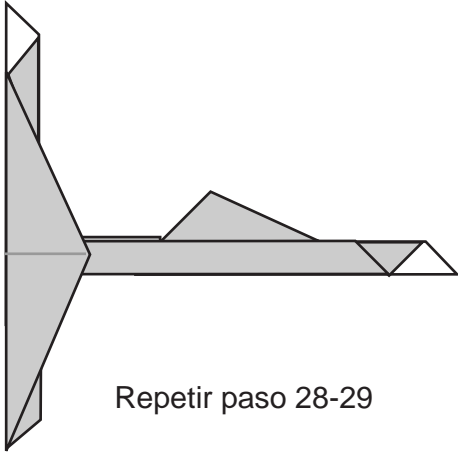

Repetir paso 28-29

31

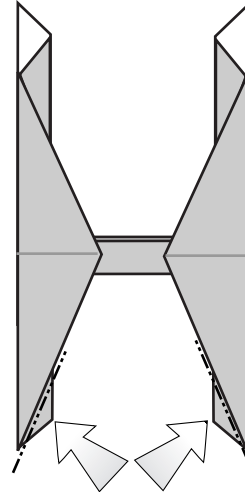

Hundir. Repetir atrás

32

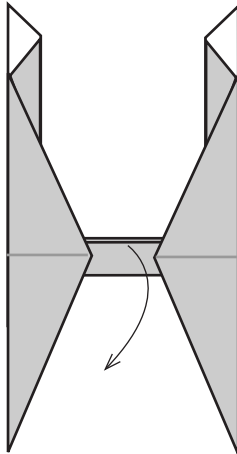

Desdoblar,
la primera capa

33

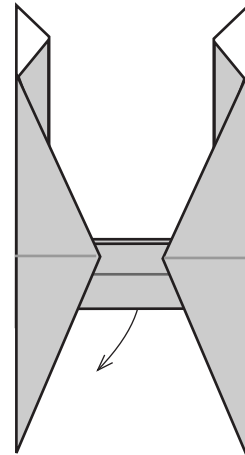

Repetir atrás

34

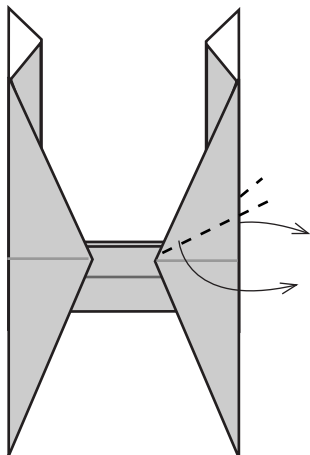

35

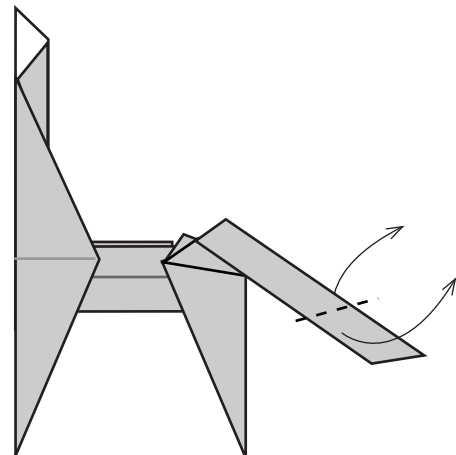

36

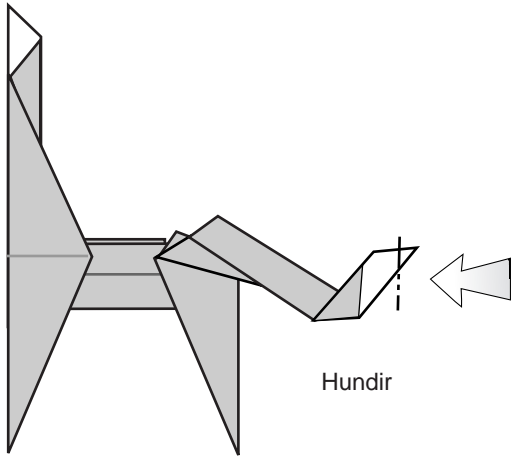

Hundir

37

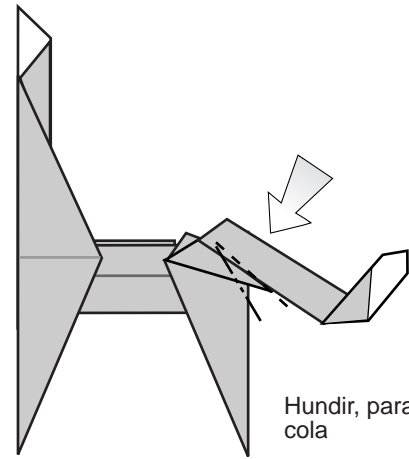

Hundir, para bajar la cola

38

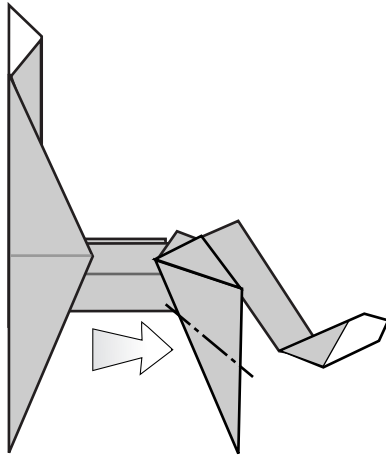

Hundir por el centro. Repetir atrás.

39

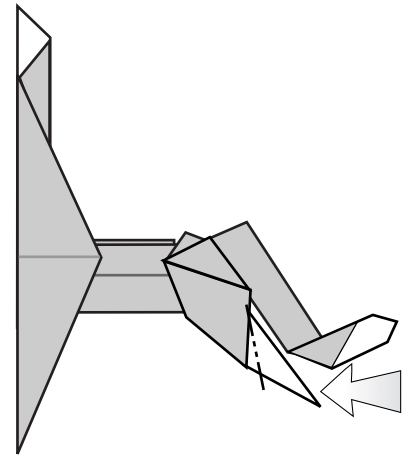

Volver a hundir por el centro. Repetir atrás.

40

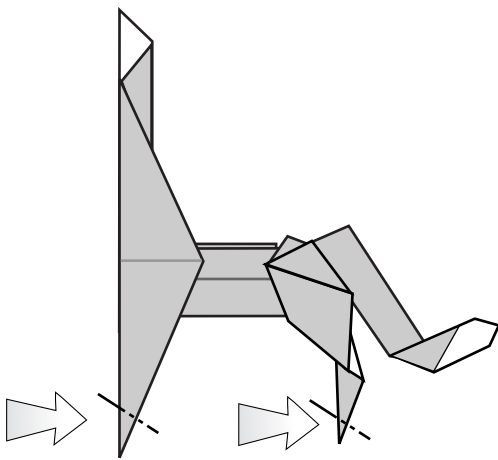

Hundir por el centro. Repetir atrás.

41

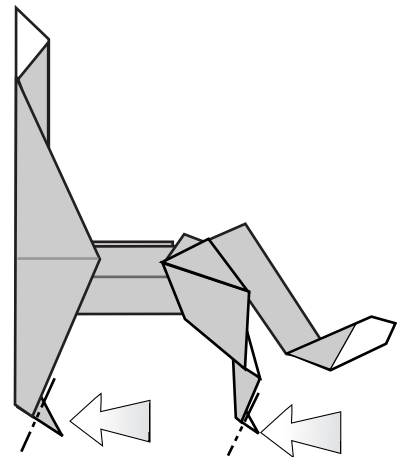

Repetir atrás.

42

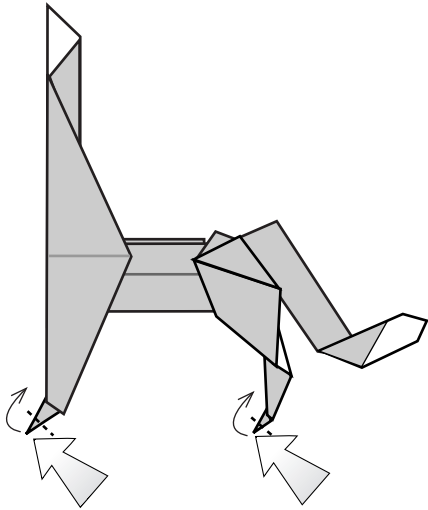

Doblar cubriendo la punta.
Repetir atrás

43

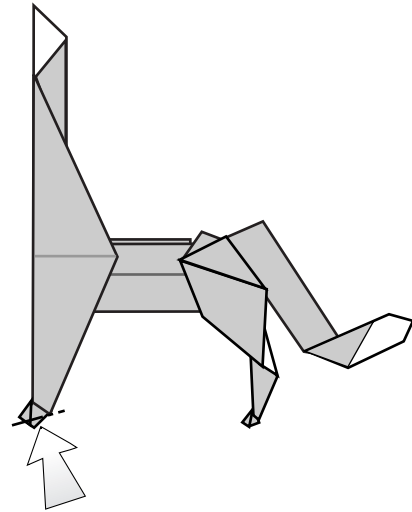

Afinar garra de las pata
delantera. Repetir atrás

44

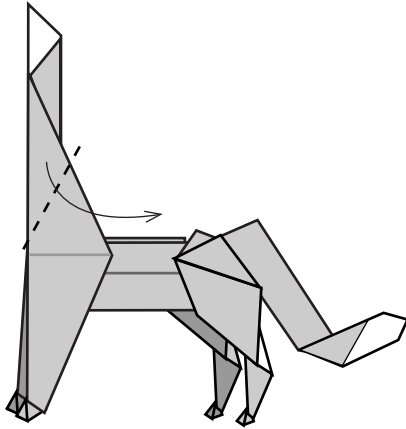

Doblar hacia adelante

45

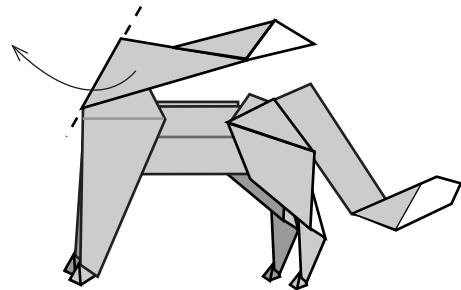

Volver al paso 42

46

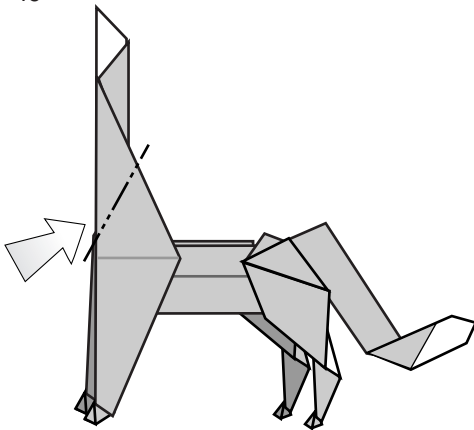

Hundir por el centro

47

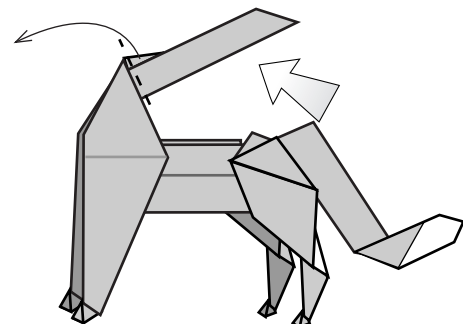

Doblar hacia adelante

48

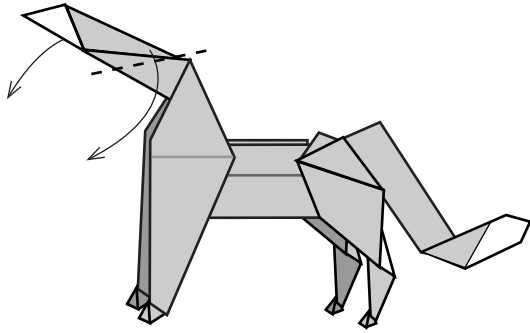

Doblar hacia abajo para formar la cabeza

49

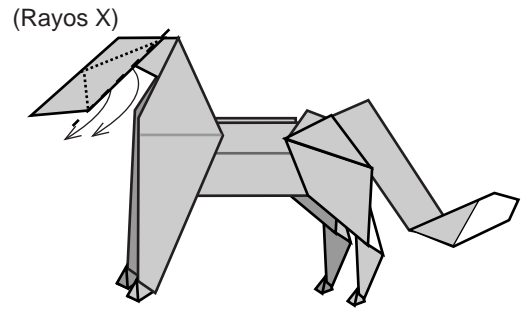

Desdoblar capa oculta. repetir atrás.

50

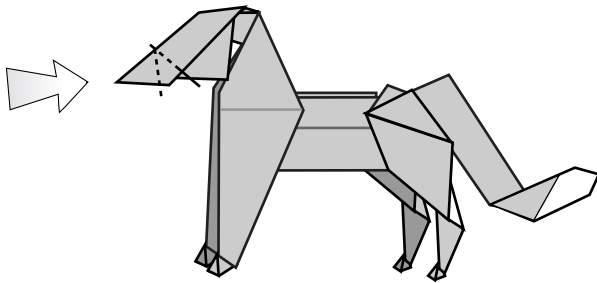

Hundir.

51

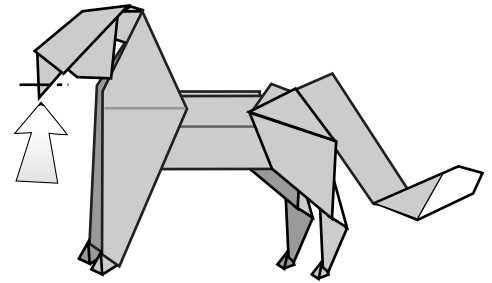

Hundir.

52

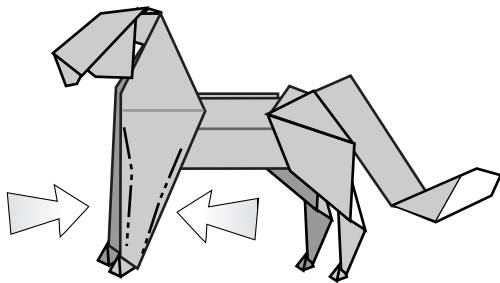

Modelar pata delantera. repetir atrás

53

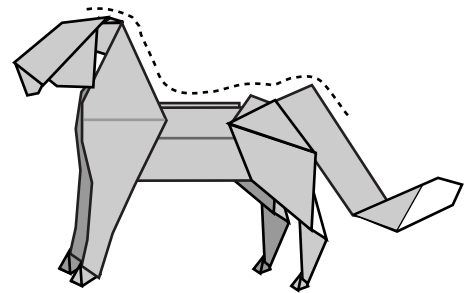

Dar volumen a la figura, Redondear orejas

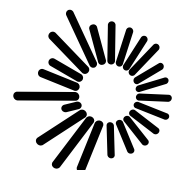
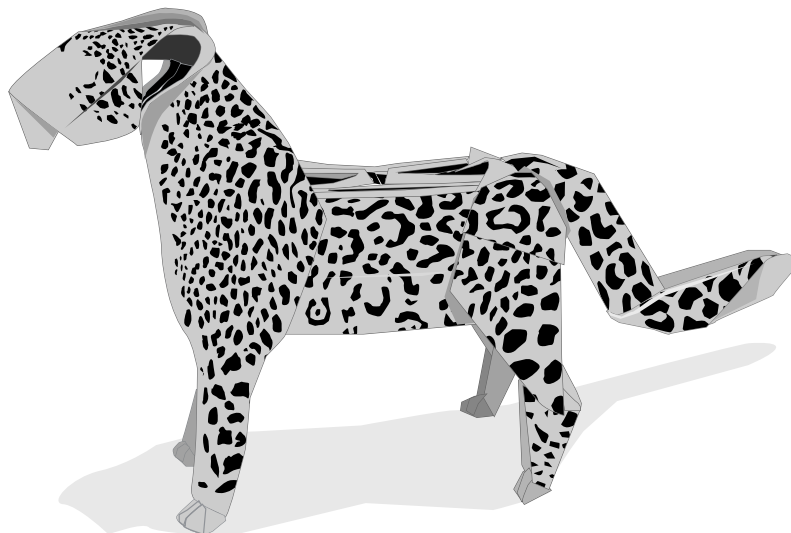

ORIGAMI
chile

www.origamichile.cl