

CONDORITO

Patricio Kunz Tomic 2003 ©

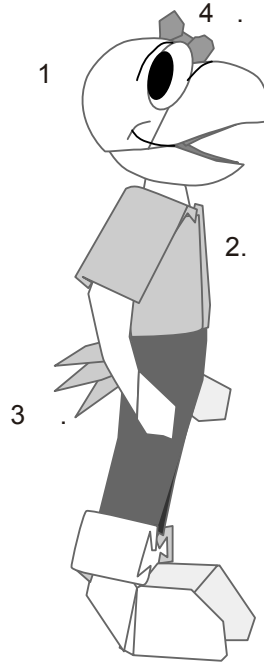
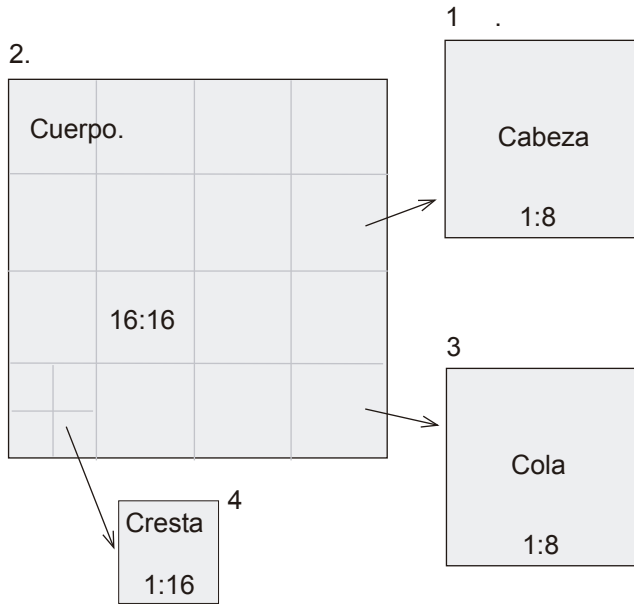

Este modelo se compone de cuatro partes: La cabeza, el cuerpo, la cresta y la cola.
Las proporciones son de 1:8 del cuerpo para la cabeza y la cola y de 1:16 para la cresta.

Cabeza

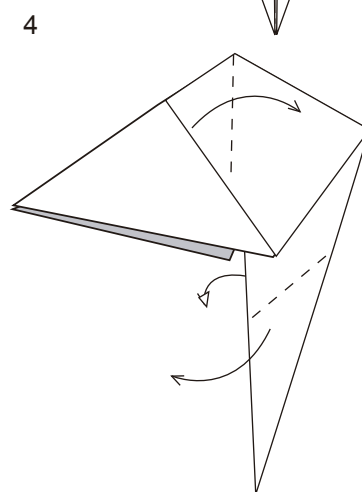
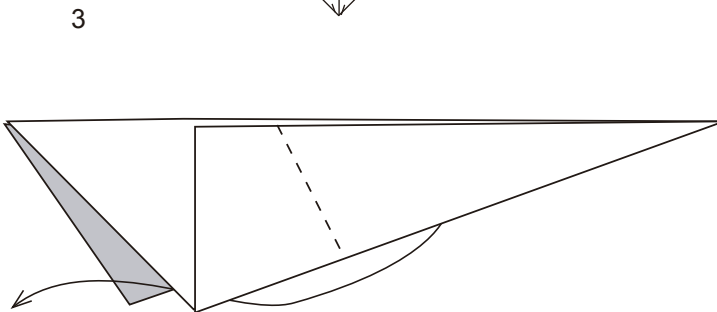
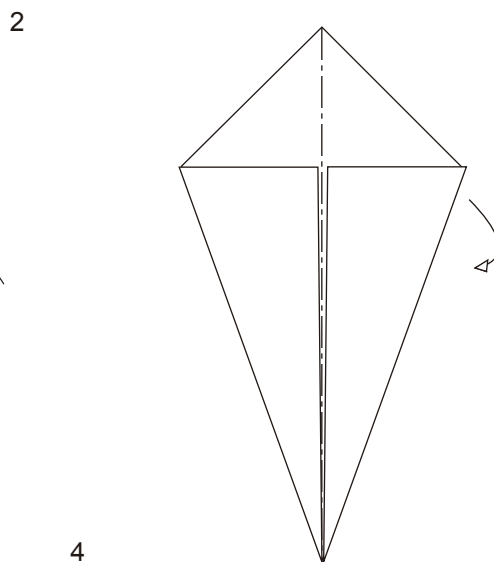
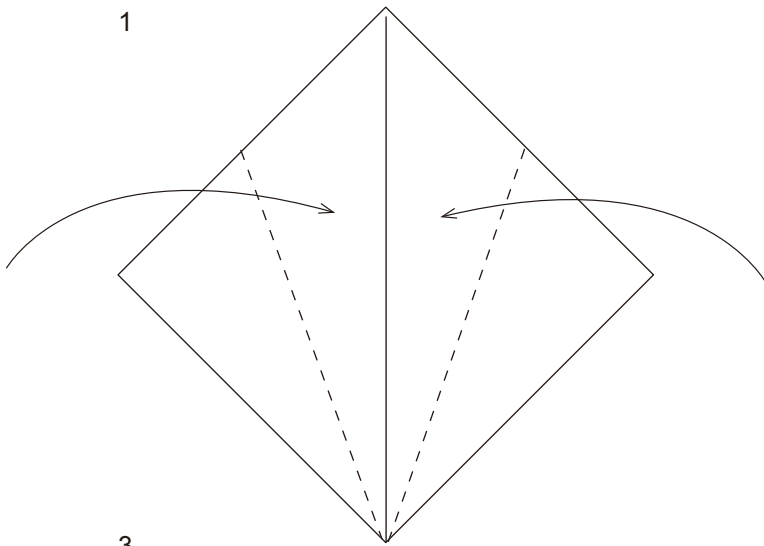

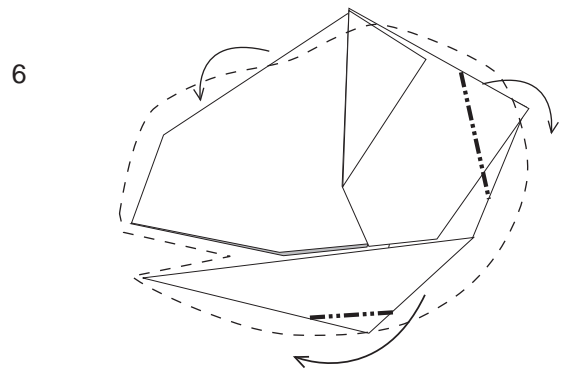
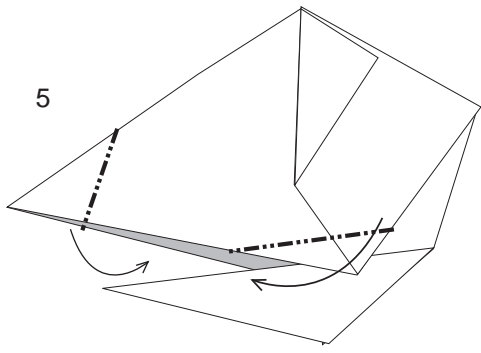

(Redondear cara)

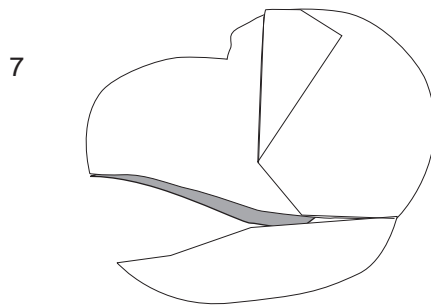

(Dar volumen a la Cabeza)

Cresta

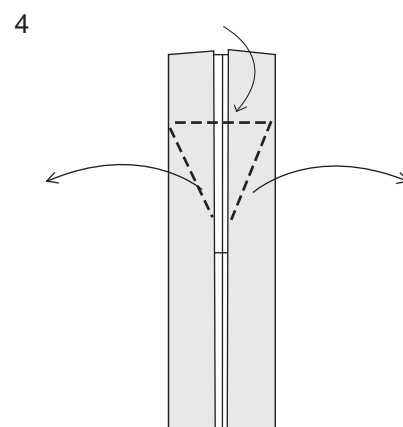
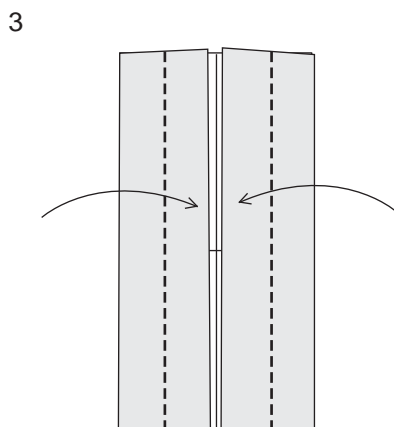
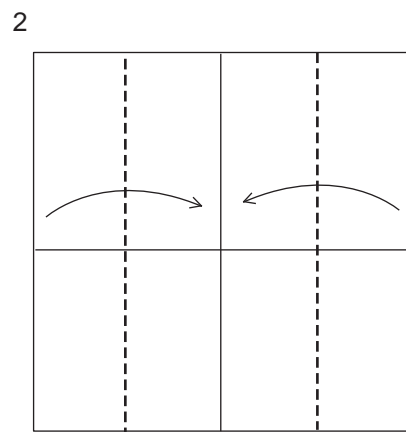
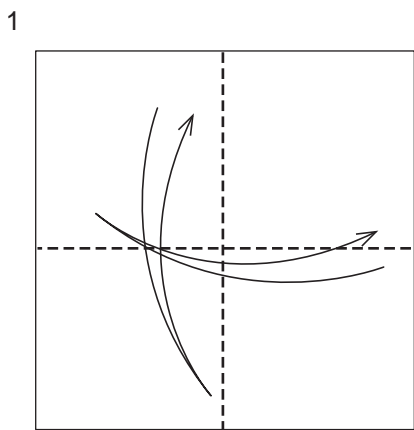

(doblar un poco antes de la mitad)

5

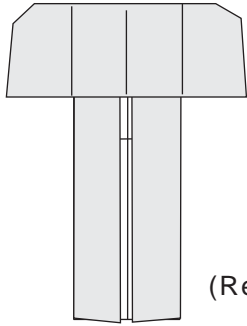

(Repetir paso 4 en parte inferior)

6

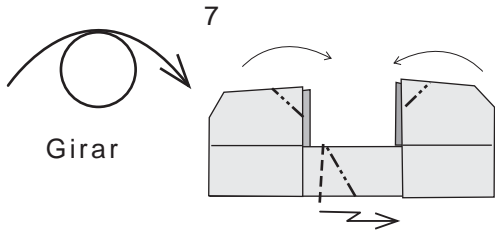
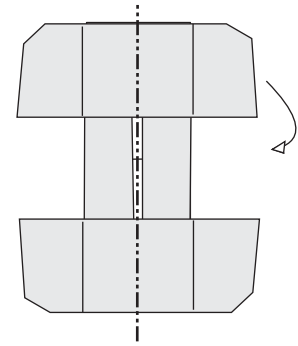

8

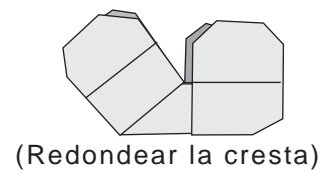

Cuerpo

1

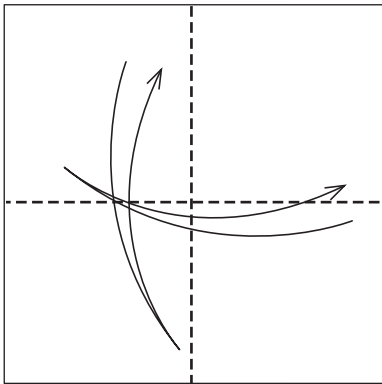

2

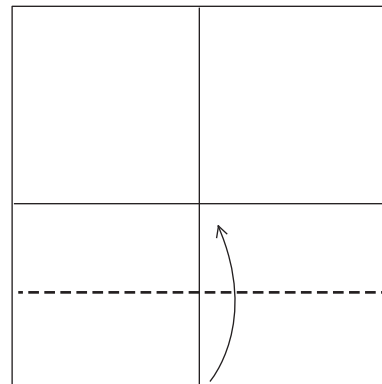

3

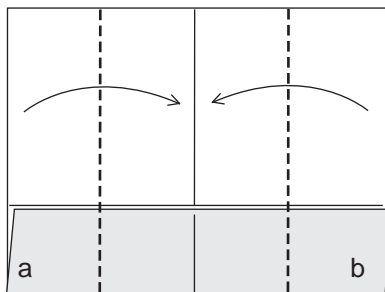

4

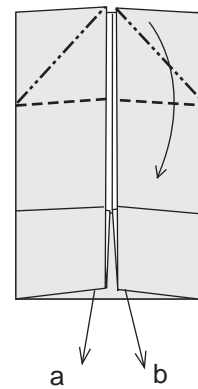

5

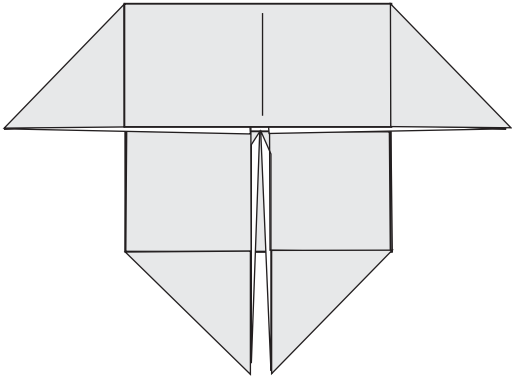

6

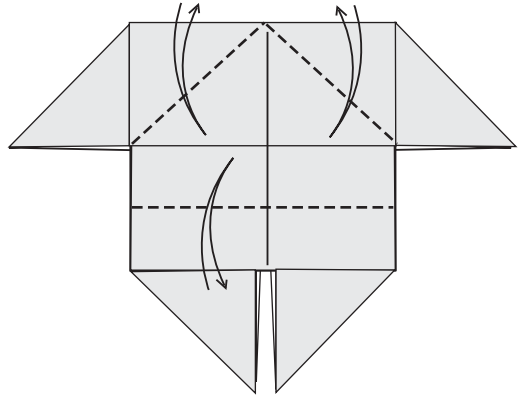

7

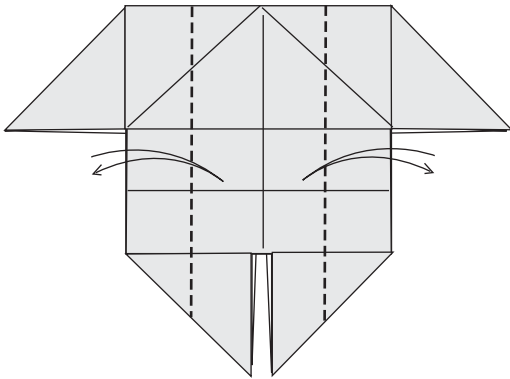

8

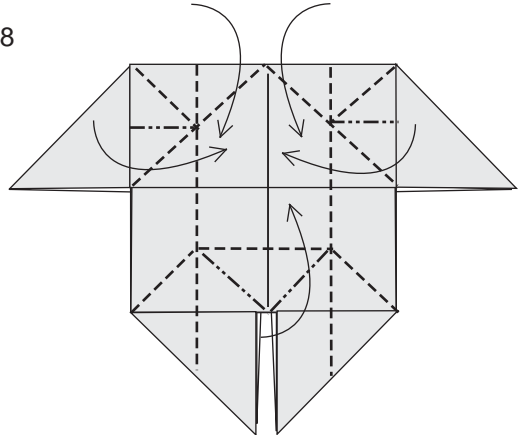

9

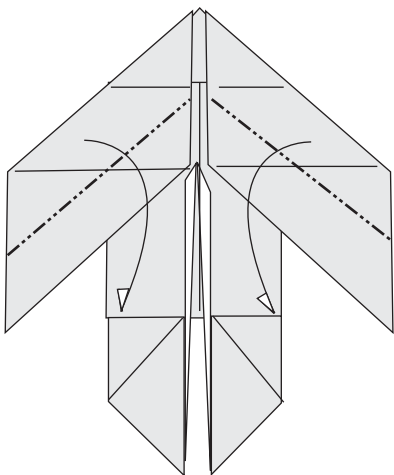

10

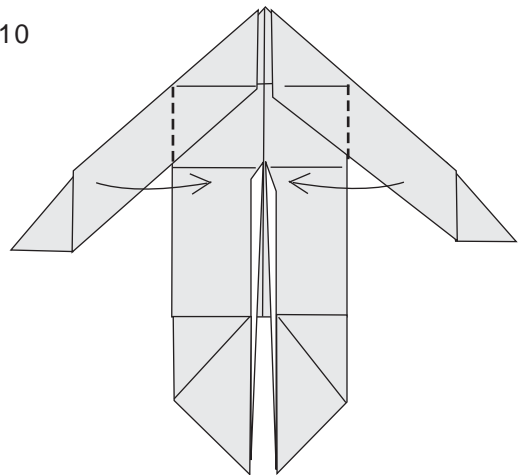

11

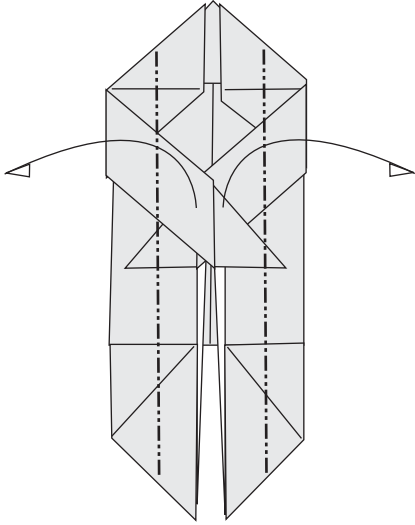

12

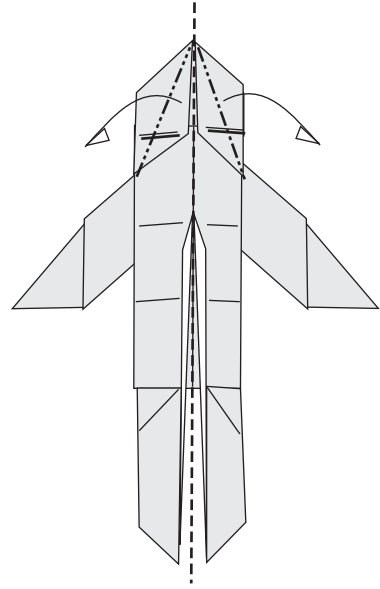

13

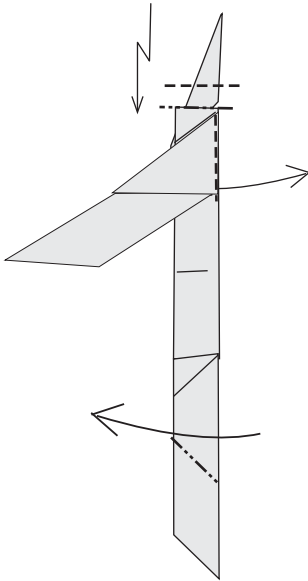

14

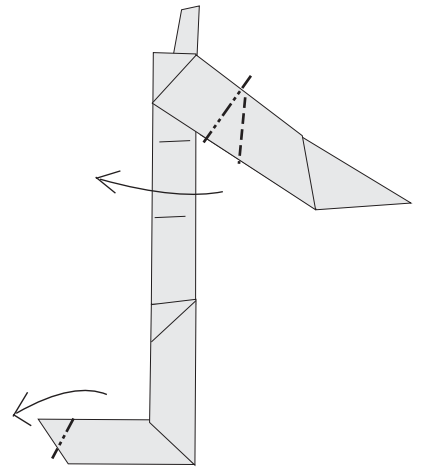

15

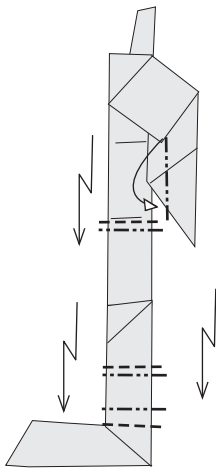

16

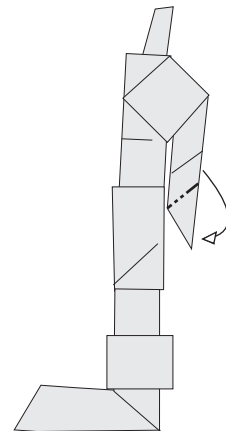

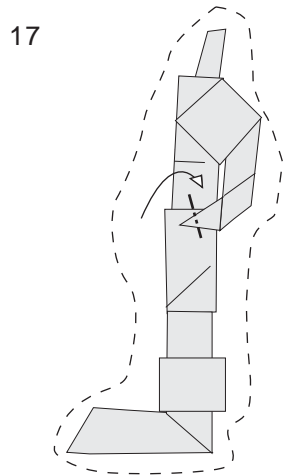

(Redondear la Figura)

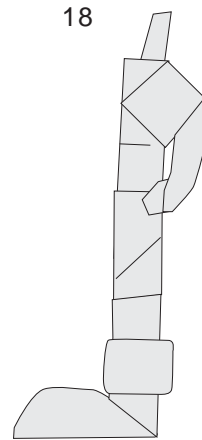

Cola

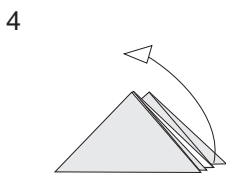
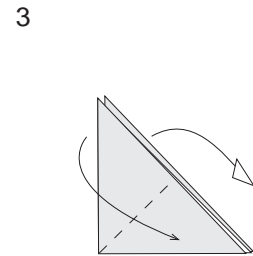
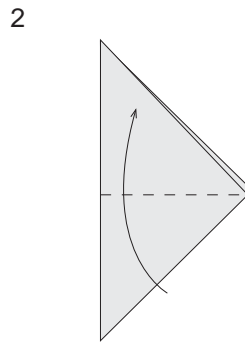
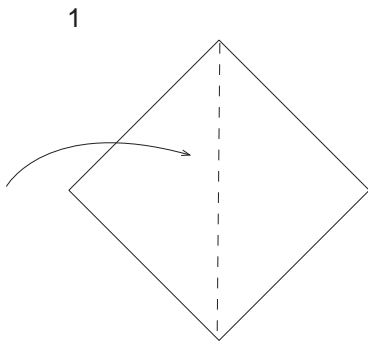

(Tirar la capa del medio)

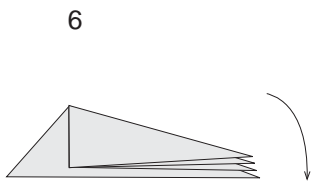
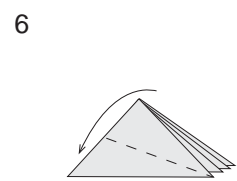
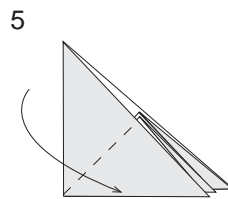

(Separar Plumas)

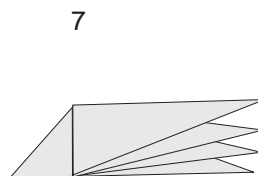

Armado

... Colocar la cresta sobre la cabeza..

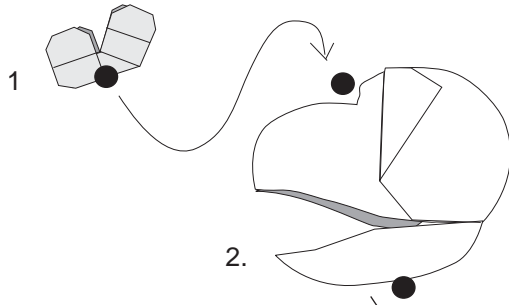

... Colocar la cabeza sobre el cuello...

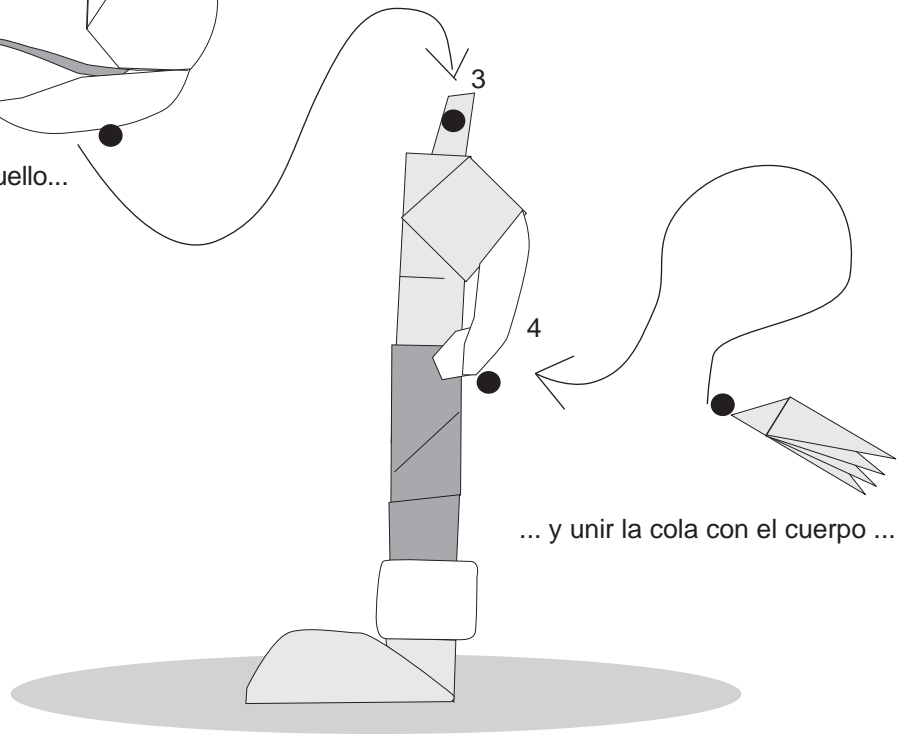

patokunz@hotmail.com

... Dibujar ojos y facciones para darle mas realismo al personaje...

CONDORITO

